

# RUBBER-MOUNT UNFRAMED GLASS

SINGLE or DOUBLE SLIDING WINDOW

# FS-36

**EXTERIOR VIEW**  
R. H. SHOWN - L. H. OPPOSITE

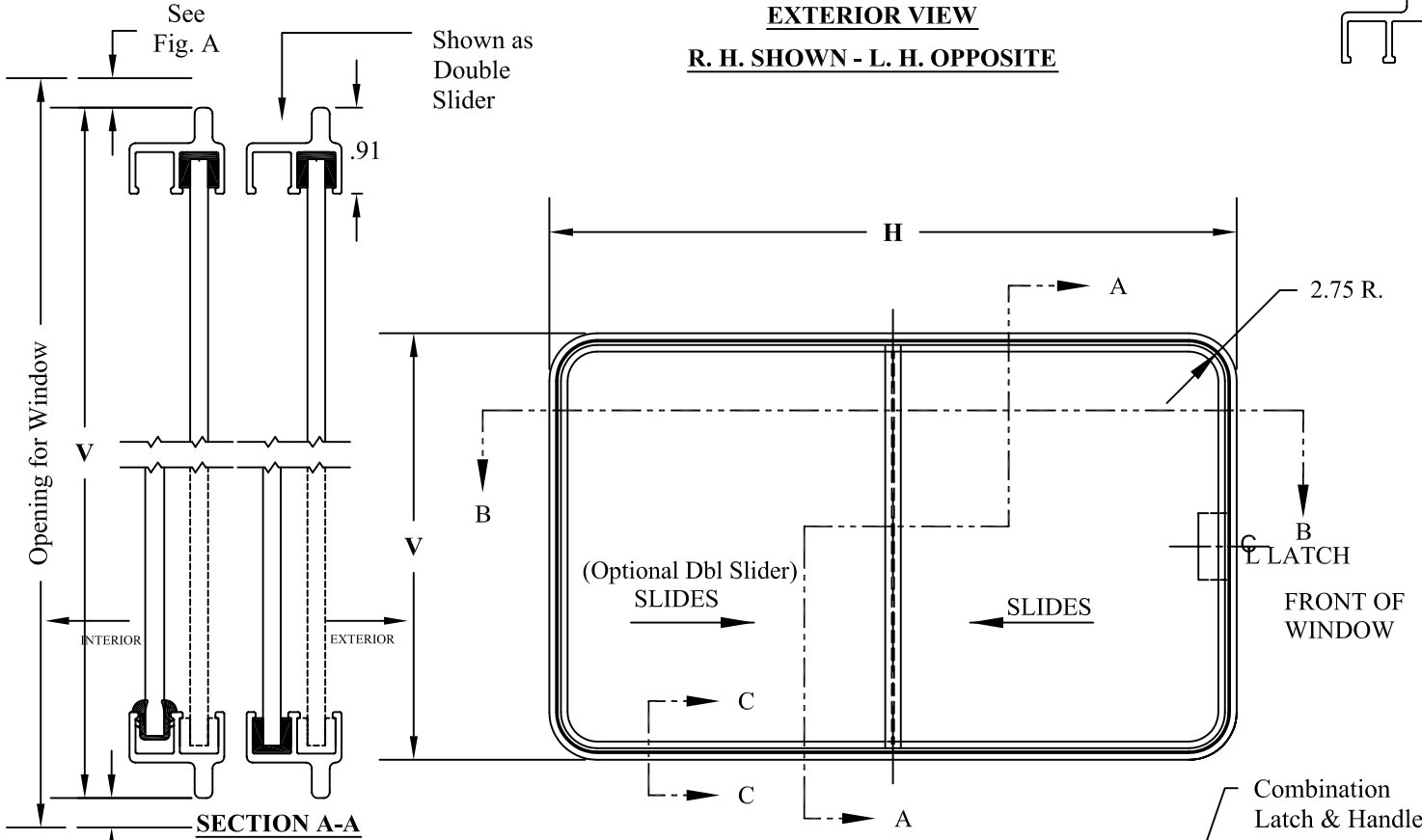
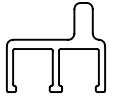

**SECTION A-A**

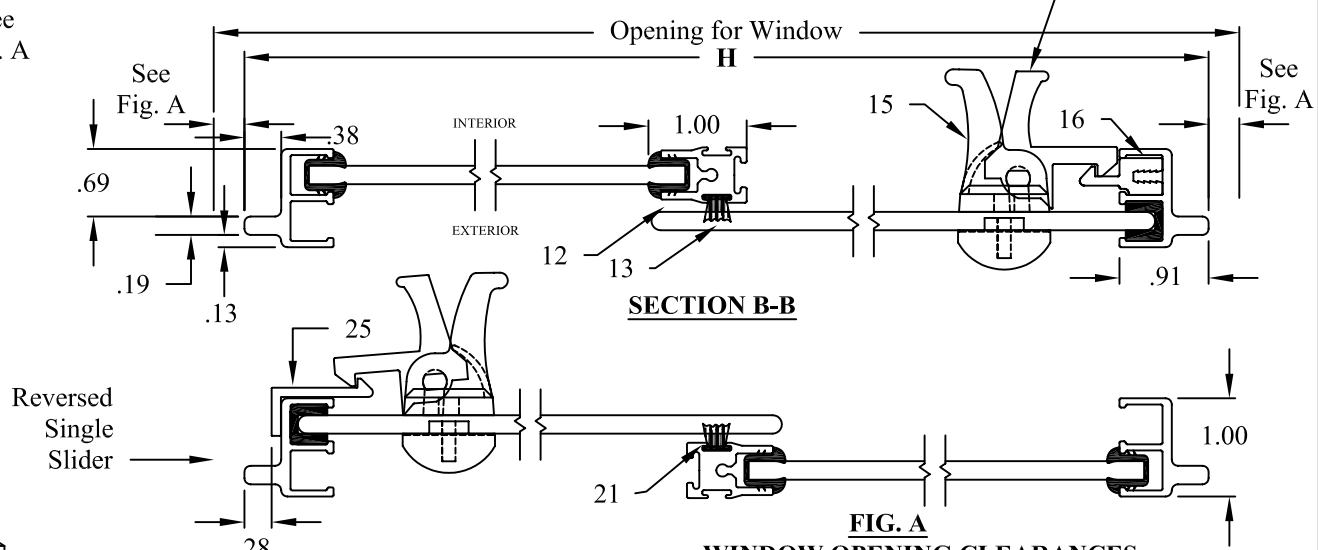

**SECTION B-B**

**FIG. A**  
**WINDOW OPENING CLEARANCES**

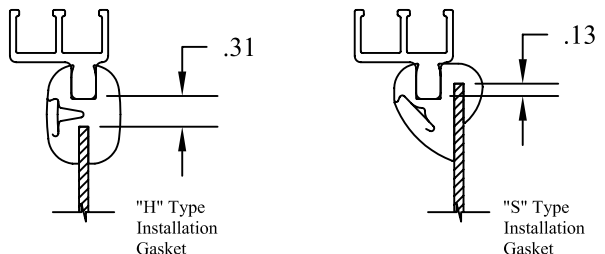

Recommended clearance between window assembly and body opening. Clearances will vary from supplier to supplier. These types of installation gaskets, with clearances shown, can be supplied with windows upon request.

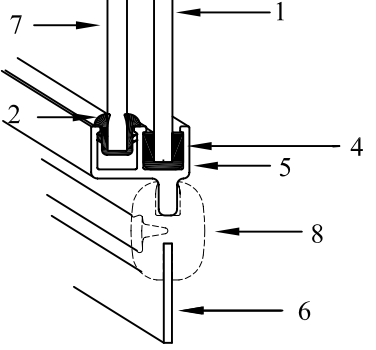

- KEY TO NUMBERED PARTS**
1. Sliding glass
  2. Vinyl glass channel
  4. Felt slide channel
  5. Outer Frame
  6. Vehicle Wall
  7. Stationary glass
  8. Installation gasket
  12. Vertical Rail
  13. Felt Pile Weather Seal
  14. Rubber Weather Seal
  15. WP70 Combination Latch & Handle
  16. Latch Keeper
  21. Vertical Rail-Double Slider
  25. Latch Kpr-Double Slider
  29. Latch Spring

# FS-36 WINDOW FEATURES

# STANDARD SHAPES

Window frame is mounted to vehicle body panel with an extruded rubber installation gasket. Sliding glass moves inside a felt lined channel. Easy operating handle latches and unlatches the slider pane(s) in the same motion used for opening and closing the window. Drain slots, where necessary, and weather seals keep wind and water outside. This window can be manufactured in various shapes, sizes, and sliding configurations.

## ORDERING INFORMATION

**GLAZING:** 3/16" Clear Tempered Safety Glass (Std)

**Options:**

3/16" Tempered Glass Light Green or Medium Gray Tint\*

1/4" Tempered Glass- Clear, Light Green or Med Gray Tint\*

3/16" or 1/4" Polycarbonate or Acrylic in various tints

\*Additional Tints available upon request

**FRAME FINISH:** Clear Anodized (STD)

**Option:** Flex Black Paint

**CORNER RADIUS:** 2.75" (STD)

**Options:** 2.00"

2.25"

3.00"

**LATCH:** WP4 Squeeze Latch Assembly (STD)

Rack & Ratchet -Vertical Slider Only

(See "Window Parts" items 12 & 13)

WP1 Combo Latch/Handle with Hold Open

(Illustrated below)

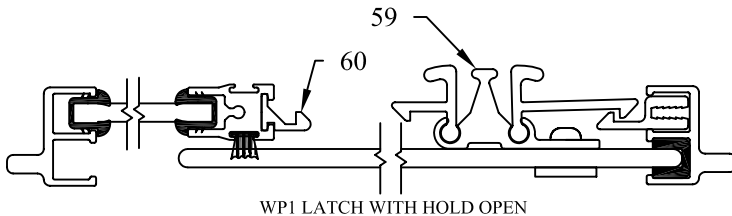

WP1 LATCH WITH HOLD OPEN

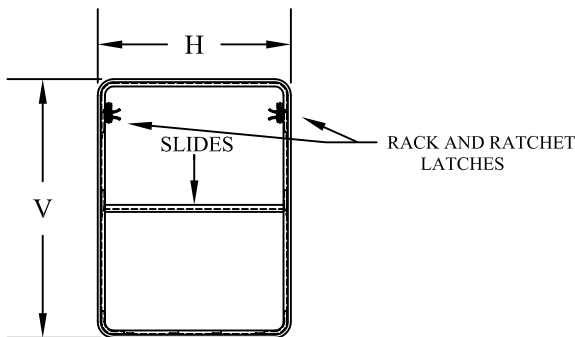

FS-36V-2

## EXTERIOR VIEW

R. H. SHOWN - L. H. OPPOSITE

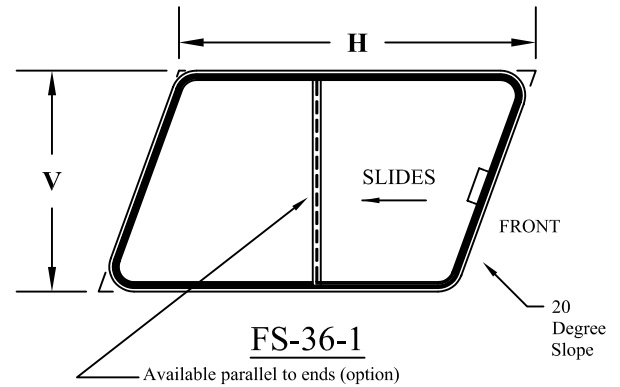

FS-36-1

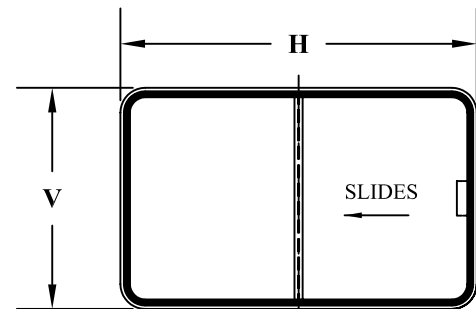

FS-36-2

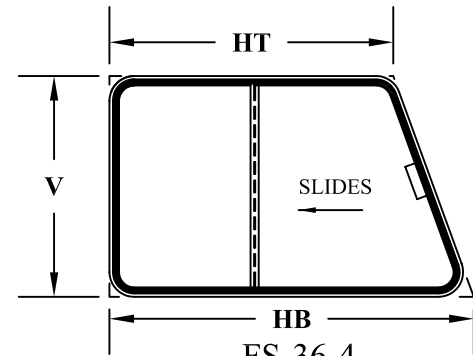

FS-36-4

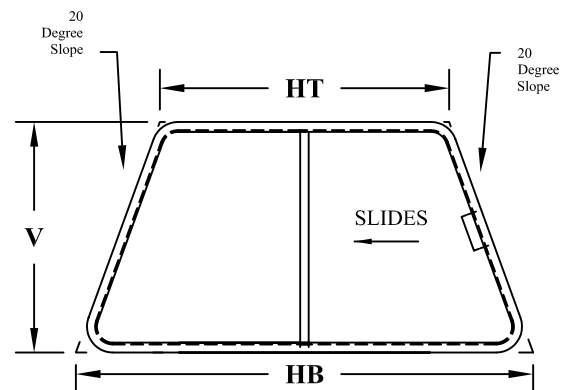

FS-36-5

Transportation Products, Inc.

P. O. Box 586

Evergreen, Al 36401

Phone: (251) 578-1267

Fax: (251) 578-5213

E-mail: tpi@tpiwindows.com

# FS-36