

CLAMP RING-MOUNT UNFRAMED GLASS

SINGLE
SLIDING WINDOW

FS-59

EXTERIOR VIEW
R. H. SHOWN - L. H. OPPOSITE

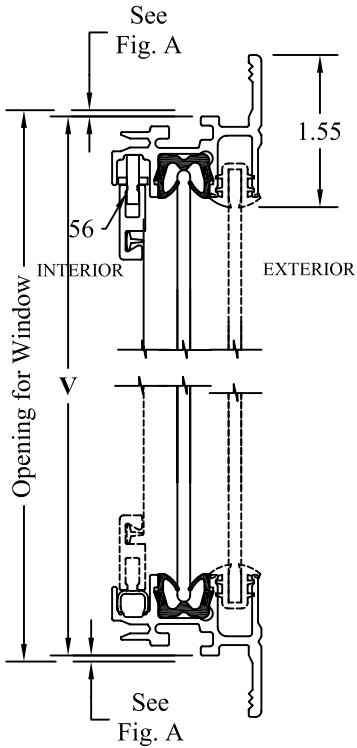
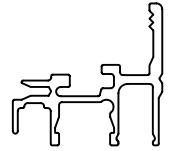

SECTION A-A

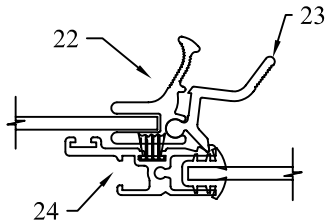
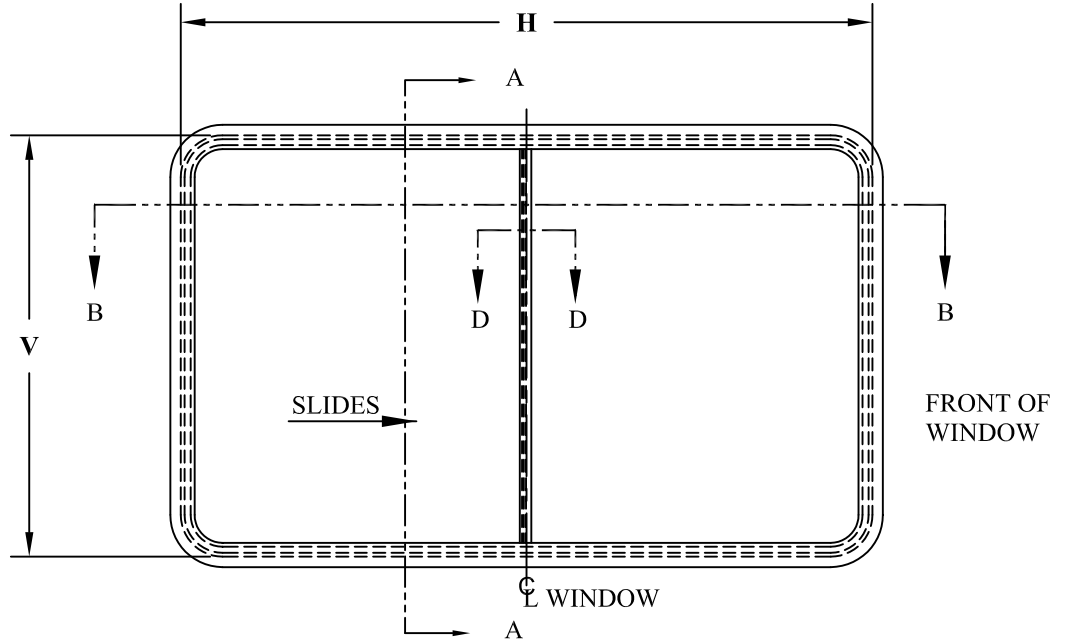

SECTION D-D
Optional Center Latch

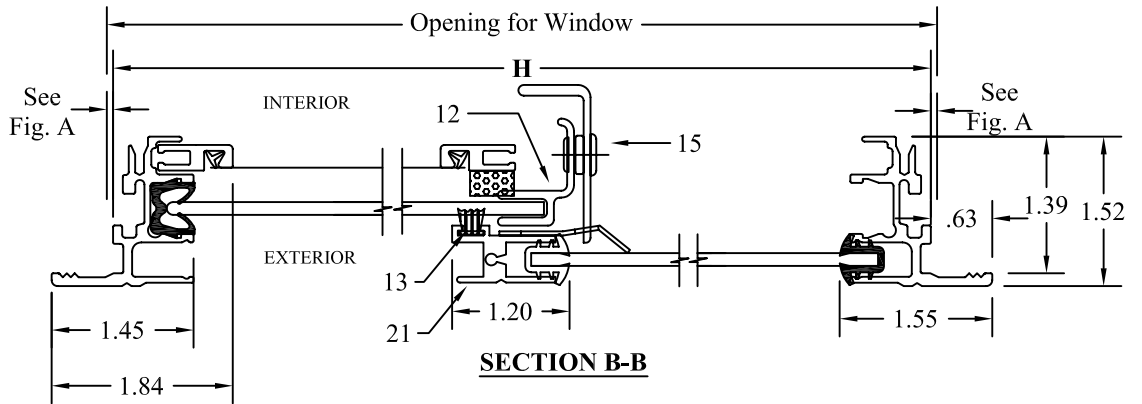

SECTION B-B

FIG. A
WINDOW OPENING CLEARANCES
Selection of optional interior trim ring requires additional allowance for window opening as shown.

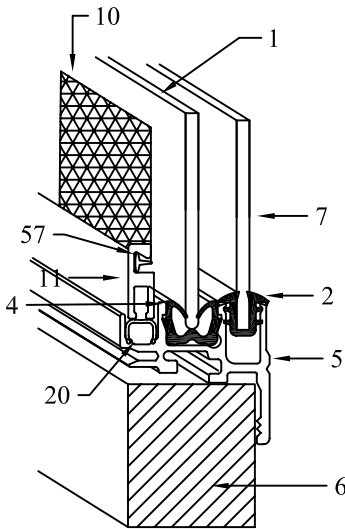

KEY TO NUMBERED PARTS

1. Sliding glass
2. Vinyl glass channel
4. Felt slide channel
5. Outer Frame
6. Vehicle Wall
7. Stationary glass
10. Screen
11. Screen Frame
12. Latch Rail
13. Felt Pile Weather Seal
15. Window Twist Latch
17. Trim Ring-Option
20. Screen Run -Glide
21. Vertical Rail
22. Center Squeeze Latch,Opt
23. Center Latch Leaf
24. Latch Rail, Squeeze Latch
56. Screen Spring Clip
57. Screen T Spline

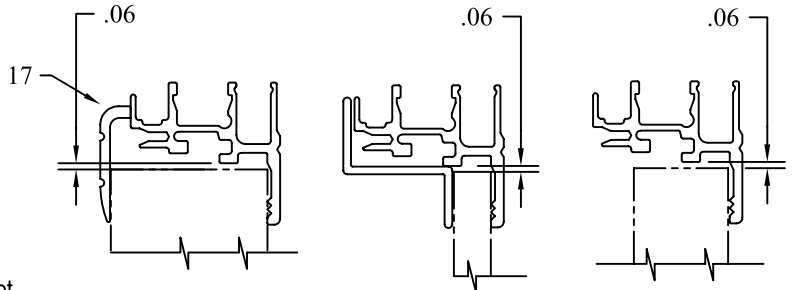

Trim ring installed
for walls greater
than .50".

Trim ring installed
for walls less than
or equal to .50".

W/o trim ring
installed -
Flange Mount

Versatile design allows a broad range of window types. Stationary, Top-T Slider or Vertical Slider. Choice of slide or twist latch. Screen may be fixed or sliding. Sliding glass moves inside a felt lined channel. Drain slots, where necessary, and weather seals keep wind and water outside. This window can be manufactured in various shapes, sizes, and sliding configurations.

ORDERING INFORMATION

GLAZING: 1/8" Clear Tempered Safety Glass (Std)

Options:

1/8" Tempered Glass Light Green or Medium Gray Tint*

1/8" Polycarbonate or Acrylic in various tints

*Additional Tints available upon request

FRAME FINISH: Clear Anodized (STD)

Option: Flex Black Paint

CORNER RADIUS: 2.50" (STD)

LATCH: Center Twist Latch (STD)

Option: Center Squeeze Latch

EXTERIOR VIEW

R. H. SHOWN - L. H. OPPOSITE

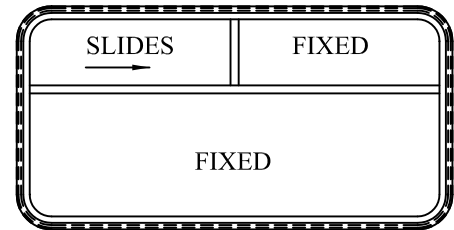

FS-59 A-2

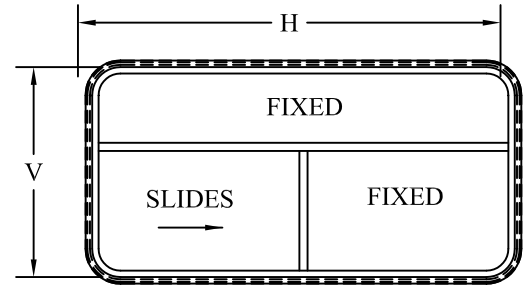

FS-59 B-2

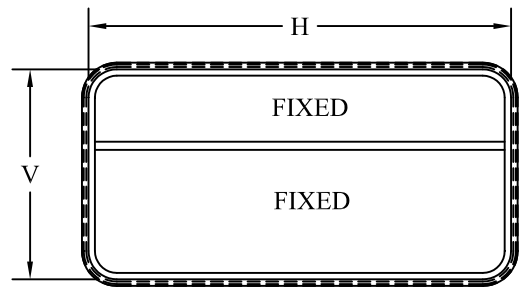

FS-59 C-2

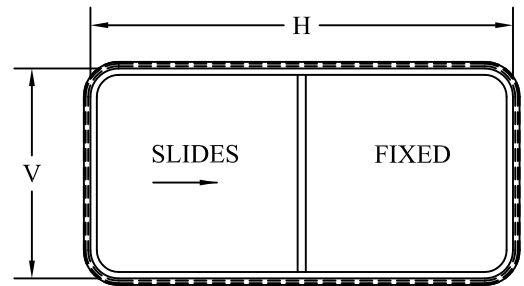

FS-59 D-2

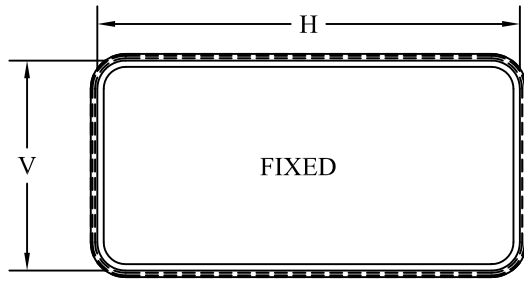

FS-59 E-2

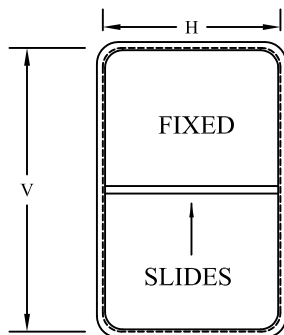

FS-59 V-2