

FLANGE-MOUNTED UNFRAMED GLASS

STATIONARY
WINDOW

FS-63

INTERIOR VIEW
L. H. SHOWN - R. H. OPPOSITE

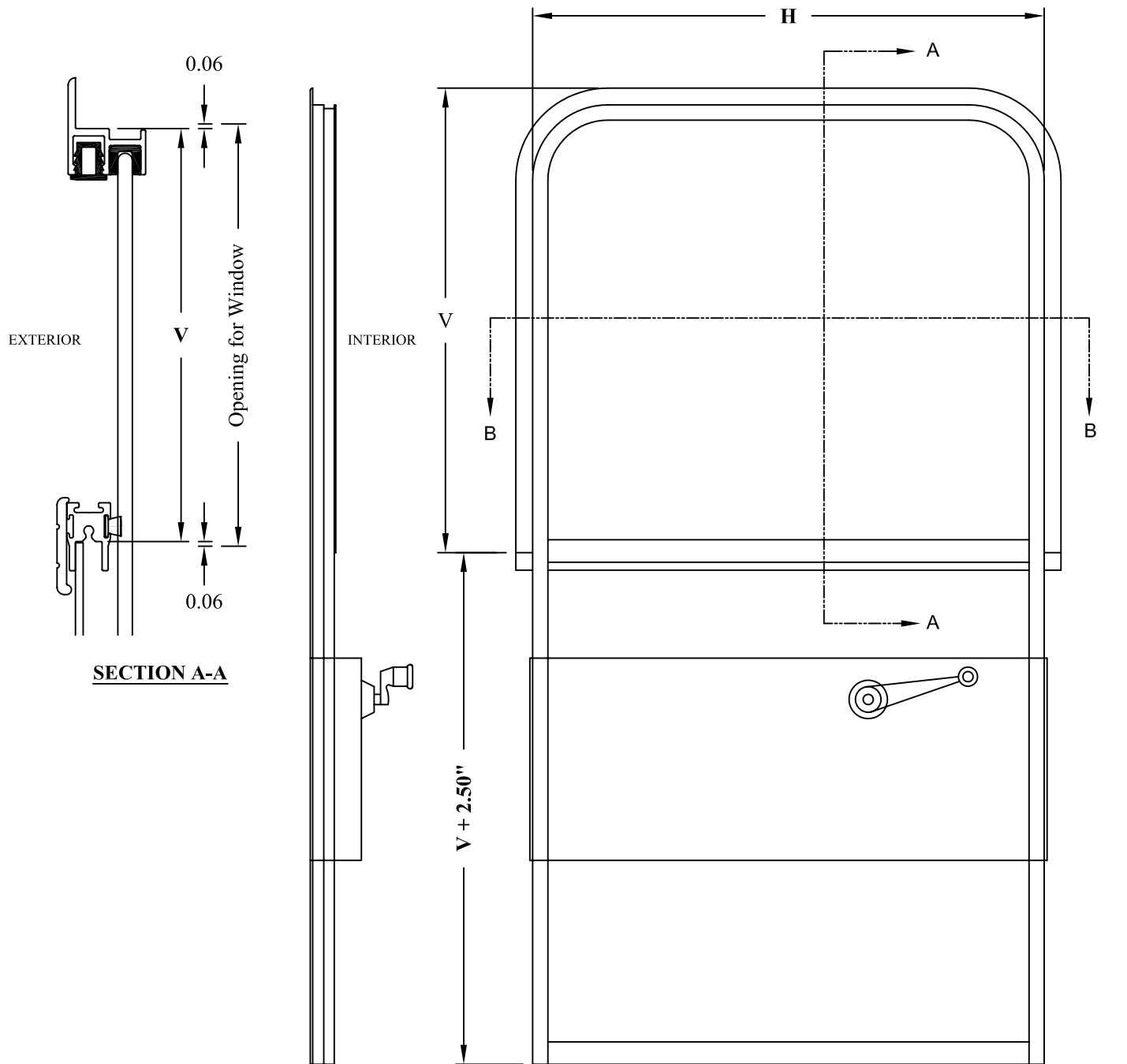

SECTION A-A

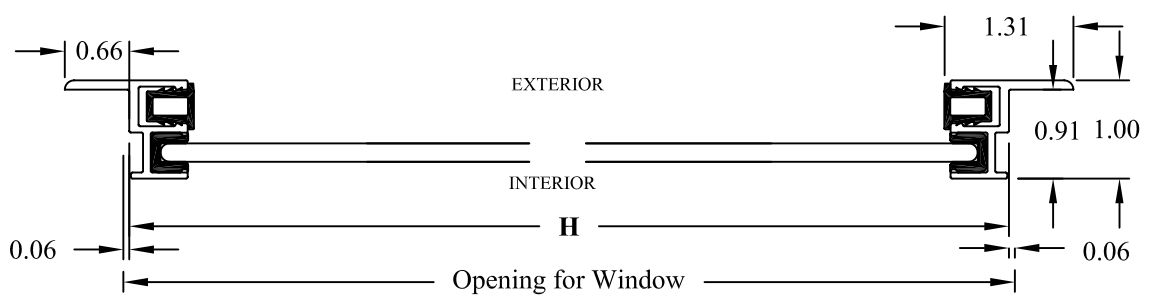

SECTION B-B

FS-63 WINDOW FEATURES

Designed for use in driver's door, vertically sliding glass is positioned by crank type automotive window regulator. May be adapted to other locations in the vehicle.

ORDERING INFORMATION

GLAZING: 3/16" Clear Tempered Safety Glass (Std)

Options:

3/16" Tempered Glass Light Green or Medium Gray Tint*

*Additional Tints available upon request

FRAME FINISH: Clear Anodized (STD)

Option: Flex Black Paint

CORNER RADIUS: 2.94" (STD)

Optional Radii: 3.13"

3.94"

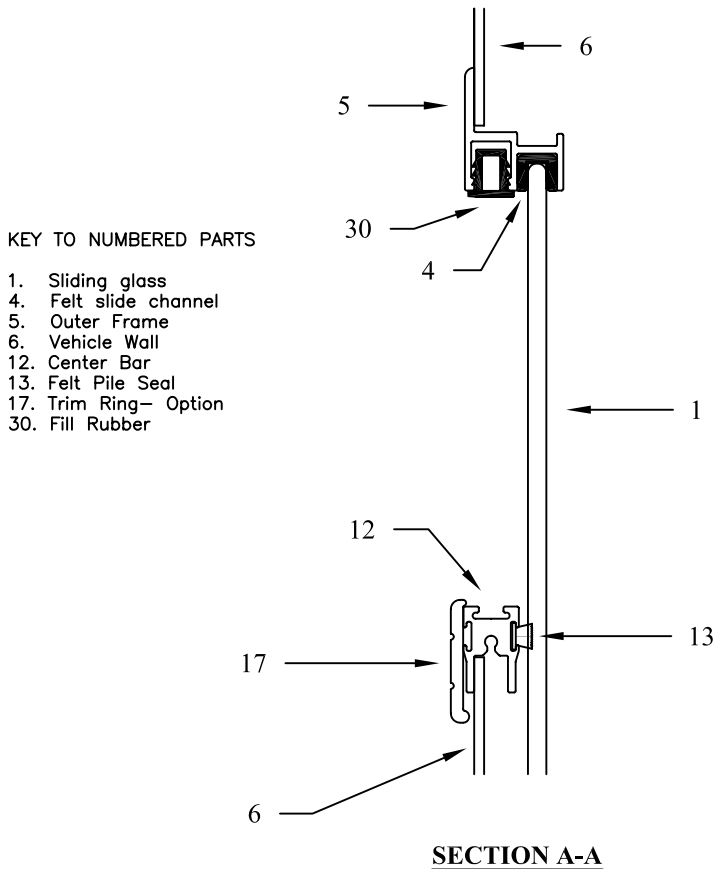

Transportation Products, Inc.
P. O. Box 586
Evergreen, Al 36401

Phone: (251) 578-1267
Fax: (251) 578-5213
E-mail: tpi@tpiwindows.com

FS-63